

Quick Guide

1. Before Installing

Congratulations on purchasing your **AudioCodes 405HD GbE IP Phone**! Before you begin using the phone, make sure that the following items are included in the shipped box:

- ✓ 405HD GbE IP Phone
- ✓ AC power adapter (optional)
- ✓ Cat 5e Ethernet cable
- ✓ Phone base stand
- ✓ Handset
- ✓ Handset cord

2. Physical Description



3. Cabling the Phone



Warning: Prior to connecting power, refer to the *Compliance and Regulatory Information* document at <https://www.audiocodes.com/library/technical-documents>.

To cable the phone (refer to the illustration below):

1. Connect the short, straight end of the phone cord to the handset and the longer straight end of the cord to the handset jack on the phone.
2. (Optional) Connect a headset to the RJ-9 headset port, or to the USB port.
3. Connect the RJ-45 Internet port to your LAN network (LAN port or LAN switch/router) with a CAT 5 / 5e Ethernet cable.
4. Connect the RJ-45 PC port to a computer with a CAT 5 / 5e straight-through Ethernet cable.
5. Connect the connector tip of the AC power adapter to the phone's DC 5V power socket and connect the two-prong AC adapter directly to the electrical wall outlet. When the phone powers up, all the LEDs momentarily light up.

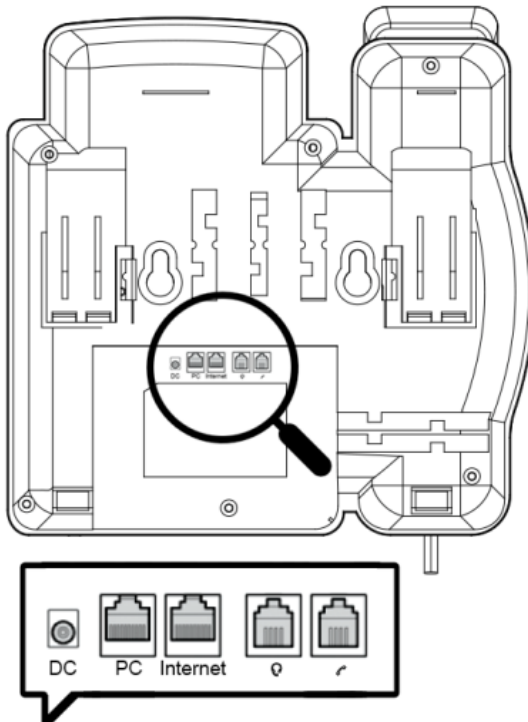



4. Mounting

You can mount your phone on a desktop or on a wall.

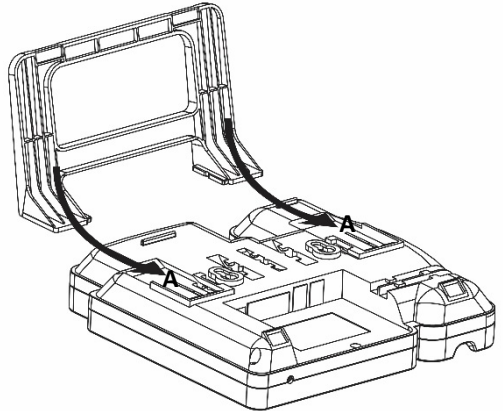
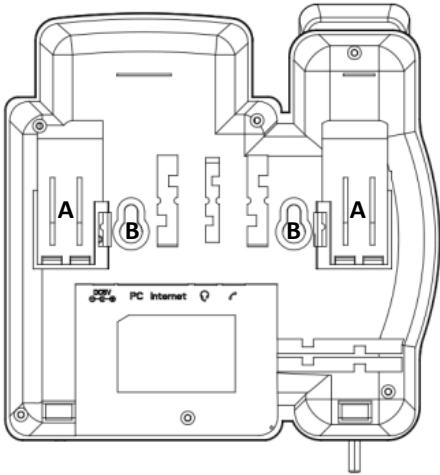
- ✓ **Desktop mounting:** Slide the short edges of the L-shaped stand (the prongs) into the phone's two rear slots (see **A** below). Slide the prongs in until they lock.
- ✓ **Wall mounting:** Hook the phone's two rear notches (see **B** below) onto wall mounting screws. Pull out the handset's cradle clip, which is by default in desktop mounting position, invert it, and then push it back in. This is the wall mounting position.



5. Operating the Phone

- ☞ **To make a call:** Pick up the handset, enter a phone number and then press the **Dial** softkey. To call a phone contact, press the directory icon  softkey, access the Corporate or Personal directory, select the contact and then press the **Dial** softkey.
- ☞ **To redial a number:** Press the **REDIAL** key, select a dialed number, and then press the **Dial** softkey.
- ☞ **To answer a call:** Pick up the handset or press the **Accept** softkey.
- ☞ **To end a call:** Onhook the handset or press the **End** softkey.
- ☞ **To put a call on hold and make another call:** Press the **Hold** softkey and then the **New Call** softkey, enter a phone number and press the **Dial** softkey. To return to the held call, press the **Resume** softkey.
- ☞ **To transfer a call:**
 1. During a call, press the **TRANSFER** key, enter the phone number of the party to whom to transfer the call, and then press the **Dial** softkey.
 2. After that party answers, press the **Trans** softkey.
To perform blind transfer, consult your IT manager.
- ☞ **To mute a call:** Press the mute  key. To resume the conversation, press the mute key again.

☞ To automatically forward incoming calls to another phone:

1. Press the **Forward** softkey (in the idle screen).
2. Select the condition upon which you want calls forwarded - **Always**, **Busy** or **No Reply**. If you choose **No Reply**, define after how many seconds the call is forwarded if not answered.
3. Enter the number to where you want to forward the calls, and then press the **Start** softkey.

To deactivate call forwarding, press the **Forward** softkey.

☞ To make a 3-way conference call:

1. Make a call to the first participant in the conference call.
2. Press the **Conf** softkey and then make a call to the second participant.
3. When the second party answers, press the **Conf** softkey.

To end the three-way conference call, hang up the phone or press the **End** softkey.

Notice Information

Information contained in this document is believed to be accurate and reliable at the time of printing. However, due to ongoing product improvements and revisions, AudioCodes cannot guarantee accuracy of printed material after the Date Published nor can it accept responsibility for errors or omissions. Updates to this document can be downloaded from <https://www.audiocodes.com/library/technical-documents>.

This document is subject to change without notice.

Date Published: Feb-25-2018

Document #: LTRT-12162

